

# Journal of Human Resource and Leadership (JHRL)

**Effects of Compressed Work Schedule on Performance of Public Universities in Mount  
Kenya Region**

Mercy Kanyua Mwiti and Lucy Kagwiria Mwirigi



**Effects of Compressed Work Schedule on Performance  
of Public Universities in Mount Kenya Region**

 Mercy Kanyua Mwiti  
Meru University of Science and Technology  
 Lucy Kagwiria Mwirigi  
Meru University of Science and Technology

**Article History**

*Received 17<sup>th</sup> March 2025*

*Received in Revised Form 16<sup>th</sup> April 2025*

*Accepted 27<sup>th</sup> May 2025*



How to cite in APA format:

Mwiti, M., & Mwirigi, L. (2025). Effects of Compressed Work Schedule on Performance of Public Universities in Mount Kenya Region. *Journal of Human Resource and Leadership*, 10(2), 1–18. <https://doi.org/10.47604/jhrl.3360>

**Abstract**

**Purpose:** Compressed work schedule is one of flexible working arrangements on employee performance in public universities in Mount Kenya region. The Objective of the study was to establish how remote/teleworking affects employee performance of Public Universities in Mount Kenya region;

**Methodology:** The study was guided by the hypothesis: There is no statistically significant relationship between compressed work schedule and employee performance of public Universities in Mount Kenya region. The target population of the study were 3,012 employees of public Universities in Mount Kenya region consisting of teaching and non-teaching staff. The sample size was 353 respondents determined by use of Yumane formulae. The study employed descriptive research design. The open-ended questionnaire was used as the main data collection instrument. Data analysis and interpretation was based on descriptive statistics and inferential statistics. In addition, a multiple regression model was used to explore the relationship between the variables under study. A pilot test will be carried out in a public University outside Mount Kenya region to ensure validity and reliability of the data collection instruments prior to actual collection of data. The data was analyzed using SPSS software version 28. Descriptive statistics were presented in frequency tables, percentages, mean, standard deviations and graphs. Inferential statistics were used in testing null hypotheses.

**Findings:** Results showed that teleworking and employee performance of public universities were positively and significantly related ( $\beta=0.380$ ,  $p=0.000$ ). The study concluded that there was a statistically significant relationship between teleworking, and employee performance of public universities in Mount Kenya region.

**Unique Contribution to Theory, Practice and Policy:** The study recommends that Managers should improve the use of flextime work arrangement because it enhances employee performance, reduces absenteeism and increases employee satisfaction. Universities should also build flexible arrangements since they help employees in managing their work load, their personal life and help them to assess their responsibilities.

**Keywords:** *Compressed Work Schedule, Employee Performance, Public Universities*

©2025 by the Authors. This Article is an open access article distributed under the terms and conditions of the Creative Commons Attribution (CC BY) license (<http://creativecommons.org/licenses/by/4.0>)

## INTRODUCTION

Out of the emerging issues in business world and also the current Covid 19 pandemic which has affected the performance of various public universities, employees are expected to balance between personal life and work responsibilities that is if the employee performance is to be achieved. Employee performance is important in this global age as it boosts productivity (UNICEF, 2019).

Compressed work schedule is a form of flexible working arrangements/schedules and Universities can decide to use the methods that suit them well (Bhusan & Sar, 2020). The organization flexibility is considered a key element in organizational behavior in terms of retaining employees' productivity as well as organizational performance. Organization flexibility is of importance in improving organization performance by increasing job satisfaction among the workers (Saunders & Townsend, 2018).

According to Omondi and Obonyo (2018) provision of flexible work schedules relies on the ability to enhance recruitment, retention, job satisfaction, commitment and reduction of work-life conflict among employees. It makes sense that offering work-life balance practices would attract individuals in universities, and that using these practices would result in improved employee attitudes and behaviors. According Liu and Wu (2016) the development of technology and modernization of society and business, managers are becoming more likely to provide employees with flexible working arrangements. And this is where employees are given a chance to choose their work time and work places. Since flexible working conditions give more freedom to both employers and employees, they are widely accepted by white-collar workers in different working fields, such as finance, insurance, information technology (Reilly 2009).

Compressed schedule work is important and significant to workplaces in this twenty first century. Organizations are troubled with how to balance their employees work-life balance so as to improve on effective and efficiency in the organization performance (Austin, Egole, Iheriohanma, & Nwokorie, 2020). Compressed work schedule carries a lot of benefit to the organization in that is there is lower office head cost, there is increase in diversity and inclusivity and also employees are able to manage their responsibilities outside work.

Traditional work schedules have been characterized by 8 to 5:00 P:M heavy work schedules, struggles with transport movement, struggles with money, high cost of living and at times mental health issues. Many employees work in urban areas hence requiring flexible ways of navigating the modern work environment and the changing world around them. In order for the teleworking arrangement to work in a public university a policy document should be in place since this document will clearly show the roles expectations and the deadline that one is supposed to observe, this document should be agreed upon by the managers. In the current situation of pandemic there are many opportunities that managers can consider in the remote working that allows workers to take on a caring responsibility without having to give up on work for example in an employee caring for vulnerable people (Sharafizad, Paull, & Omari, 2011). Allowing flexibility in the workplace will help the employee to keep working while balancing the demand of life teleworking will bring about motivation to the employees this is because one tends to work beyond the call of duty and they feel more motivated to work hard and give back to the organization. The main reason

as to why most institutions are embracing teleworking it is because this will bring a win working relations which appreciates the needs of both the employer and employee (UNICEF, 2019).

### **Organization Performance**

Organizational performance comprises the actual output or results of an organization as measured against its intended outputs or goals and objectives. According to Richard et al. (2009) organizational performance incorporates three specific areas of organization aftermaths: financial performance, product market performance, shareholder return. Geert Scheipers (2016), contends that organization management is the process of ensuring that the organization resources are correctly used in regard of the set goals. The concept of performance management is commonly applied to employee development.

The managerial and executive staffs also need to develop a flexible working arrangements system that charts the progress of the company in the 21<sup>st</sup> century and determine when changes in policy or procedure need to be made. The vision of an organization, is in a perfect world a common way of thinking about the ideal manner by which an association capacity (Reilly 2009). This is known at every level and is translated into individual behavior or performance at work. If the vision of an organization is merely “delegated” by top management to employees or worse, communicated via an ambiguous and generic campaign, the vision will never carry enough weight to motivate ((Rooplal, 2017).

In order to ensure perfect congruence between the organization and its employees, managers must organize sessions wherein employees actively participate in internalizing the overall vision of the company. He also states that the top management may know the long term goals of the organization, a deeper understanding of the vision however may be solely understood and translatable by experts in the field. In changing business environments, the organizational learning process is a necessary skill in order to realize strategic change on the flexibility working arrangements.

Neely (2002) believes that performance should consider quantifying the efficiency and effectiveness of actions. This quantification can be expressed both qualitatively and quantitatively. According to the definition of other researchers and other authors, performance is closely related to efficiency and effectiveness.

### **Public Universities in Kenya**

Public universities are owned by the state and its usually receives public funds through the treasury. The Ministry of Education (MoE) controls all the public universities. Public Universities usually enroll Students after completing the 8-4-4 system of education and attaining the set mark. The University sector is one of the most rapidly expanding sector due to the demand for university education which has continued to increase with many students.

Currently we have 30 public Universities, which provides people with an opportunity to reflect on the critical social, economic, cultural, moral and spiritual issues facing humanity. It contributes to national development through dissemination of specialized knowledge and skills (Small, 2008). Public universities also have created employments to many this has enabled it possible for the universities to deliver their mandate well (Forgasz & Leder, 2006). Public Universities were not

spared either by the effect of COVID- 19, the Universities need to embrace the FWA in order to ensure smooth learning of the institutions and to achieve the set targets in the performance contracts (Mayer and Tikka, 2008).

### **Statement of the Problem**

Public Universities in Mt. Kenya region are faced with many problems that are affecting their performance. Frequent students and employees unrest, limited educational resources and recently interruption of academic programmes brought by the global Covid-19 pandemic. One of the greatest lessons learnt from the pandemic is coming up with flexible work arrangements to minimize loss and wastage of working hours. Therefore, universities have embraced the flexible working arrangements for the workers, and also encouraging a blended method of learning to ensure students complete their studies as scheduled.

The literature reviewed have revealed the importance of FWA of employees in hospitals (Jane, Simon & Amos, 2015) and commercial banks in Kenya (Waiganjo, Kihoro & Mungania, 2016). From reviewed literature limited studies have been carried out to determine the effect of FWA and organization performance in the public universities in Kenya. Limited research has been carried on flexible work arrangements as a way of improving performance among universities in Kenya (Kamau, Tuwai & Kuria, 2015). Hence there exists a knowledge gap investigation of the effect of flexible work arrangement on performance of public universities in Kenya.

The above foregoing discloses that a gap in literature exists on FWA and organization performance in the Public universities in Mt. Kenya Region. This study therefore targets to fill the noticeable gap in literature by determining the effect of FWA and organization performance in Public universities in Mt. Kenya region. The study therefore, sought to answer the question. What is the effect of flexible work arrangement on employee performance in public universities in Mt. Kenya region?

### **Research Objective**

The research objective was establishing how compressed work schedule affects performance of Public Universities in Mount Kenya region.

### **Hypothesis of the Study**

To achieve the study objective, the following null hypothesis was formulated:

**H<sub>1</sub>:** There is no statistically significant relationship between compressed work schedule and employee performance of Public Universities in Mount Kenya region.

### **Scope of the Study**

The study was limited to effects of compressed work schedule arrangements on the performance of employees in public universities in Mount Kenya region. The region was selected for the study because it's among the regions in the country that has many public universities because of its high population and potential in agriculture. The data for the study was collected between the month of January and March 2022. The study mainly focused on public universities.

## **LITERATURE REVIEW**

The study used Self-Determination Theory (SDT) was developed by Ryan and Deci in the year 2000. This theory states that human beings naturally strive for a state of high motivation and engagement. It is usually the nature of human beings to pursue growth and wellbeing. Ryan and Deci identified three universal psychological needs that motivates human beings to behave in a positive way (Ryan,2000). These needs are: -autonomy, competence and relatedness. When you satisfy these needs your self-motivation grows and your well-being increases curiosity and passionate about your work and this leads to good performance and a sense of purpose in life (Deci & Ryan, 2000).

SDT take along the issue of autonomous motivation. Voluntary motivation makes employees to desire compressed work week as a form of flexible working arrangements as it leads to better productivity, new ideas (innovations) which at long run yields job satisfaction to the employees. Reeve (2012) claimed that this theory can be categorized into: autonomous which relates to relationships such as family, controlled motives such as power and instrumental which relates to achieving specific goals. He further said that for productivity, controlled employee turnover, job satisfaction and customers' satisfaction employees should be motivated through issues like flexible working arrangements (Ryan & Deci, 2017).

This theory was important on employees who work few days in a week because it helps in determining employee performance in any given organization (Deci & Ryan, 2012). This theory also proposed that in addition to being driven by a need for autonomy, people seek ways to achieve competence and positive connections with others. This theory has its major implication relating to intrinsic rewards, the feeling of fulfillment an employee gets as a result of engaging in the work one loves to do and also being able to work and get an extra day to take care of your family. This therefore, infers the upholding of the self-esteem and self- actualization principles that motivate individual worker's action of competence and fulfillment in the workplace.

Two Factor Theory (TFT) was developed by Fredrick Herzberg in 1959 by interviewing over 200 people who were professional in their field of expertize. The interview dealt with the question of when employees were happiest when working in their organization. In essence TFT was trying to get to the root of motivation in work place (Herzberg,1959). Organizations can leverage on their TFT to get the best performance from employees working as a team to achieve organization goals. Herzberg identified motivating factors and hygiene factors as the two critical factors in determining motivation of employees. He established that absence of HF can lead to employees work less hard where HF is not in the task itself but surrounds the task being performed. Motivator on the other hand are referred to as the factors of satisfaction (Herzberg,1966). A diagrammatic representation of TFT is illustrate

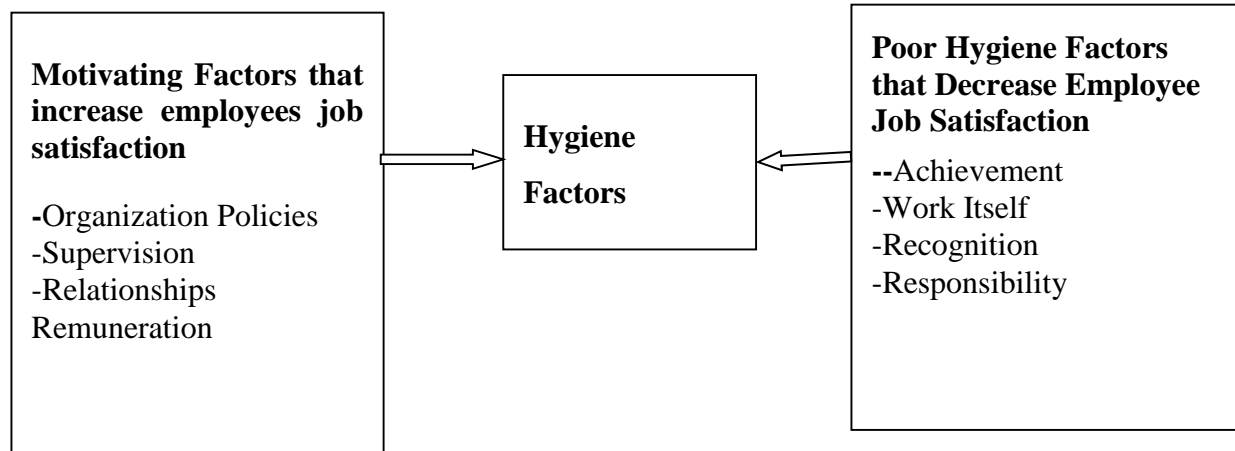

*Figure 1: Two Factor Theory*

*Source: Herzberg*

TFT further identified four stages in the organization as; high hygiene and high motivation where all employees are motivated to work and have very few grievances while in high hygiene and low motivation employees have few grievances but low in motivation. In this kind of a scenario employees are only interested in remuneration. Thirdly low hygiene and high motivation exist where workers are highly motivated but payments and working conditions are behind the competitors in the industry. In this kind of working condition remote working must be explored to improve working conditions. Finally, low hygiene and low motivation working conditions and remuneration are unattractive and employees are seeking better jobs and this leads to increased employee turn-over in institutions (Herzberg,1968).

TFT underpins the variable teleworking as it supports flexible working arrangement including the use of technology to ensure employees are highly motivated to use their knowledge and skills to achieve highest standards of performance. Therefore, the theory supported the study in identifying the role of teleworking in public universities to increase performance of of organizations (Quang,2010). Teleworkers may also come across fewer distractions as to those working from the office. The office is full of opportunities for interruptions and distractions, which in turn brings about stress to the employees and also reduce employee morale. This theory was important in the study because for employee performance to be realized motivating factor should be considered by use of flexible working methods.

### **Empirical Review**

The empirical review was based on the effects of teleworking working arrangements on employee performance in public universities in Mount Kenya region.

### **Compressed Work Week/Work Schedules and Performance**

Amendola (2011), in his study on an experiment to study compressed work week in policing, using the descriptive research design established that working on 10 hours shift has as significant higher quality of work life and more sleep than those who work 8 hours shift. Furthermore, those working

8 hours' shift are averaged earned more over time than those assigned 10-12 hours shift. In regard to the above study there is need to research on effects of FWA in public universities.

Deery (2017) in his study on “exploring the relationship between compressed work hours’ satisfactions and absenteeism in front line service work” using descriptive research design established that the compressed work hours’ satisfaction was associated with lower absenteeism that this relationship was mediated through emotional exhaustion and physical health. A number of organizations have embraced this form of working arrangements. This study identifies the role of satisfaction with compressed work week as a predictor of employee’s performance.

The study showed that there are some differences between women and men in terms of the intervening mechanisms linking schedule satisfaction and absence. The study also suggested that women usually gets more benefits than men from compressed working hours’ satisfaction because of the positive associations with physical health. Therefore, compressed working hours usually provide organization with opportunities to enrich the working lives of women in particular by reducing levels of emotional exhaustion and improving both physical health and attendance. Based on the above findings there is need to carry out a study on effects of FWA on employee performance in public universities in Kenya.

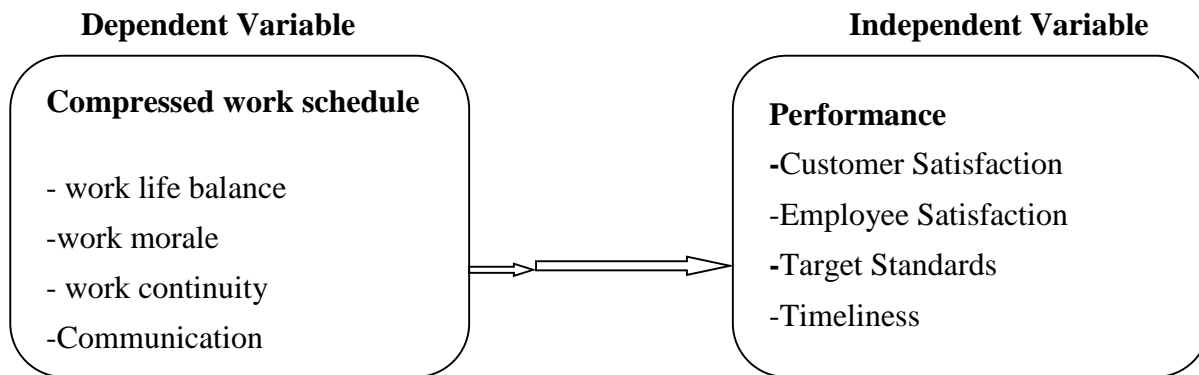

*Figure 2: Conceptual Framework*

*Source: Author*

Operationalization of variables in research is the process of defining variables under the study into measurable features. Operationalization is aimed at setting down the exact definitions of each variable under study thus, increasing the quality of the findings and improving the robustness of the research study design. It regulates how the researcher is going to measure the parameters under the study.

Compressed work schedule is an alternative work arrangement in which employees perform some portion of their regular work at a site other than the main office, using Information Communication Technology (ICT) to communicate with people inside and outside the organization (Stiles & Smart, 2021). Managers have a duty to support communication using accessible communication technology for all team members. Employees are required to have a quick line of connections to ask any queries or communicate with other team members if there is need arises. Karamanis and



Gogos (2020) established that teleworking helps to reduce absenteeism, to improve employee's morale and also to increase productivity, quality of work is seen traffic congestion is eased and better work life for the employees.

## METHODOLOGY

This study adopted descriptive research design. According to Borden's and Abbott, (2002), descriptive research design involves measuring a set of variables as they exist naturally. He further explained that this research design attempts to answer immediate questions about a current state of affairs. Mitchell and Jolley (2012), the research design provides in-depth information about the characteristics of subjects within a particular field of study. Mitchell, further argues that descriptive studies can also help identify relationships between variables. This research design adopted because of its power to determine the relationship between study variables. In this study, the independent variables were job sharing, compressed work schedules and remote/teleworking whereas the dependent variable was productivity, customer satisfaction and job satisfaction and performance of the organization.

Population refers to a clearly elaborated set of persons, elements, events, and groups of entities under investigation (Kothari, 2004). The locale of the study was of public universities in Mount Kenya regions consisting of teaching and non-teaching staff. The target population for this study was 3,012 employees in various departments in universities identified for the study. The target population was presented in Table 1.

**Table 1: Target Population**

S/No	Population per University	Teaching Staff	Non-Teaching Staff	Total Staff in the University
1	Embu University	118	266	384
2	Chuka University	280	347	627
3	Karatina University	147	264	411
4	Muranga University	150	230	380
5	Dedan Kimathi University	140	252	392
6	Kirinyaga University	142	270	412
7	Meru University of Sc. & Tec	154	252	406
<b>Total</b>		<b>1131</b>	<b>1881</b>	<b>3012</b>

Sampling technique denotes the process utilized by a researcher to select a sample depending on the quality intended by the study. If a sample is to be used, it is necessary that they be a representative of an entire population in order to get an accurate report (Barratt, 2009). Kombo and Tromp (2004), noted that a sample should have at least 30 respondents for accuracy in data analysis. Determination of sample size is guided by the need to obtain sample that is representative of the populace. The public universities in Mount Kenya region have been selected for this study by use of census technique. Simple random sampling was used to select the employees to eliminate bias and ensure that each and every element in the population has equal probability of being sampled.

Seven public universities were identified. The sample size was categorized according to the county and the sub-sectors. From the population of 3012 the study used Yumane formula to obtain sample size of 353 respondents. The sample size for the respondents was Yamane (1967) outlines the formulae below to compute the sample size.

$$\text{Sample size (n)} = \frac{N}{1 + N(e)^2}$$

N = Population size,

n = Sample Size

e= Significance Level (0.05)

n= 3012

$$(1+3012*e^2)$$

= 353.11

=353

**Table 2: Sample Size**

S/No	University	Teaching	Non-Teaching Staff	Total No. of Staff in the University
1	Embu University	14	31	45
2	Chuka University	33	41	74
3	Karatina University	17	32	49
4	Muranga University	17	27	44
5	Dedan Kimathi University	16	29	45
6	Kirinyaga University	17	31	48
7	Meru University of Sc. & Tec	18	30	48
<b>Total</b>		<b>132</b>	<b>217</b>	<b>353</b>

Source: Researcher (2021)

*Table 3: Data Analysis Matrix*

Hypothesis	Independent Variables	Dependent Variable	Statistics
H <sub>01</sub> : There is no statistically significant relationship between compressed work schedule and employee performance of public Universities in Mount Kenya region.	Compressed work schedule	Performance	t-test

The data analysis matrix is illustrated in Table 3

## RESULTS

### Response Rate

The research targeted 353 employees in various departments in public universities in Mount Kenya Region. The response rate is displayed in Table 4.

**Table 4: Response Rate**

Hospital size	Total	Response (%)
Questionnaire Returned	298	84.42
Questionnaires Not Returned	55	15.58
<b>Total</b>	<b>353</b>	<b>100</b>

A total of 298 questionnaires were totally filled and returned. Therefore, the total response rate was 84.42% which implies a successful response rate. Babbie (2004) asserted that a rate above 70% is an excellent response for the study.

**Table 5: Reliability Assessment**

Variable	Cronbach's Alpha	Number of items	Comment
Teleworking	0.817	10	Reliable

The result on Table 5 indicates that all the scaled items were above value of 0.7. Hence all the variables achieved a reliability threshold of 0.7 and above and therefore were considered adequate for this study.

Descriptive analysis for the compressed work schedule were presented in Table 6.

**Table 6: Compressed work Schedules**

Statement	Strongly disagree	Disagree	Somewhat agree	Agree	Strongly Agree	Mean	Std. Dev
My job is compressed and in line with my interests, skills and attitudes	7.70%	0.70%	20.50%	19.80%	51.30%	4.06	1.20
Compressed work week has improved your work in general	8.40%	9.40%	25.50%	26.50%	30.20%	3.61	1.24
I feel that service to customer will be affected if staffs work through compressed schedules	13.10%	5.40%	12.40%	21.80%	47.30%	3.85	1.40
I have high commitment to come to work through the implementation of compressed work schedules	9.40%	9.10%	12.80%	25.80%	43.00%	3.84	1.32
My motivation level at work can be increased through compressed work schedules	10.40%	8.70%	15.10%	22.80%	43.00%	3.79	1.35
I usually take time to follow up with clients to ensure that they are satisfied with my services.	7.40%	5.40%	16.10%	24.20%	47.00%	3.98	1.23
Compressed work schedules increases cost effectiveness and efficiency	15.10%	14.80%	22.50%	18.10%	29.50%	3.32	1.42
Compressed work week is administered effectively	12.80%	13.10%	10.70%	39.60%	23.80%	3.49	1.33
Compressed work schedules reduces employee turnover	12.80%	12.40%	17.40%	34.90%	22.50%	3.42	1.31
Compressed work schedules influence on employee performance	9.70%	2.30%	16.80%	33.90%	37.20%	3.87	1.22

Results showed that majority of the respondents who were 71.1% agreed with the statement that their job was compressed and in line with their interests, skills and attitudes (Mean=4.06, std.dev=1.20). Further results showed that most of the respondents who were 56.7% agreed that compressed work week had improved their work in general (Mean=3.61, std.dev=1.24). In addition, results showed that majority of the respondents who were 69.1% agreed with the statement that they felt that service to customer was affected if staffs work through compressed schedules. Further results showed that most of the respondents who were 68.8% agreed that they had high commitment to come to work through the implementation of compressed work schedules (Mean=3.84, std.dev=1.32). In addition, results showed that majority of the respondents who were 65.8% agreed with the statement that their motivation level at work could be increased through compressed work schedules (Mean=3.79, std.dev=1.35). Further results showed that most of the respondents who were 71.2% agreed that they usually took time to follow up with clients to ensure that they were satisfied with their services (Mean=3.84, std.dev=1.32).

In addition, results showed that majority of the respondents who were 47.6% agreed with the statement that compressed work schedules increases cost effectiveness and efficiency (Mean=3.32, std.dev=1.42). Further results showed that majority of the respondents who were 63.4% agreed

with the statement that compressed work week was administered effectively (Mean=3.43, std.dev=1.33). Further results showed that majority of the respondents who were 63.4% agreed with the statement that compressed work schedules reduced employee turnover (Mean=3.42, std.dev=1.31). In addition, results showed that majority of the respondents who were 71.1% agreed with the statement that compressed work schedules influence on employee performance (Mean=3.87, std.dev=1.22). This infers that compressed work scheduled had a positive influence on employee performance of the public universities. The study findings agreed with Njiru (2016) who revealed that compressed work hours influenced employee performance, job satisfaction and enhanced staff morale.

The respondents were further asked to indicate the some benefits of introducing compressed work week schedules. The respondents indicated that they were able to take some time off to take care of personal responsibilities.

Descriptive analysis for the performance were presented in Table 7.

**Table 7: Performance**

Statement	Strongly disagree	Disagree	Somewhat agree	Agree	Strongly Agree	Mean	Std. Dev
Performance is measured against the productivity.	11.70%	2.30%	7.00%	30.50%	48.30%	4.01	1.31
Employees show a lot of concern of seeing that they complete their day's work.	12.10%	0.00%	14.10%	27.90%	46.00%	3.96	1.30
Employees perform competently without pressure from their bosses.	9.70%	3.40%	25.20%	25.80%	35.90%	3.75	1.25
I am expected to have more individual responsibility for my job performance.	11.70%	14.10%	15.40%	32.60%	26.20%	3.47	1.33
My University emphasizes on meeting the customers' needs as results are more important than following the correct organizational procedures.	9.40%	4.00%	14.80%	38.30%	33.60%	3.83	1.21
People are flexible and adaptable when changes are necessary.	11.40%	0.70%	12.10%	27.90%	48.00%	4.00	1.29
Employee believe they can influence or affect their work place through their ideas and involvement.	4.40%	7.00%	13.40%	21.50%	53.70%	4.13	1.15
Individuals and teams have clearly defined goals that relate to the goals or mission of the University.	10.10%	5.40%	8.10%	27.20%	49.30%	4.00	1.30
We constantly stretch our goals, to continuously improve	11.40%	7.00%	9.10%	26.20%	46.30%	3.89	1.36
People know what is expected of them and understand their impact on other people, teams, and functions.	11.40%	3.00%	15.40%	34.90%	35.20%	3.80	1.27
People believe in teamwork, the "what's in it for us" approach rather than "what's in it for me."	11.70%	9.40%	13.80%	41.90%	23.20%	3.55	1.27
Managers at all levels work together as a team to achieve results for the University	10.40%	7.00%	12.80%	34.90%	34.90%	3.77	1.28
I would be happy to spend the rest of my career in this University.	5.40%	18.80%	19.10%	15.10%	41.60%	3.69	1.32
I do feel a strong sense of belonging to my University	15.40%	12.80%	7.40%	28.90%	35.60%	3.56	1.46
work overtime to complete my tasks	9.70%	2.30%	16.80%	33.90%	37.20%	3.87	1.22

The results showed that majority of the respondents who were 78.8% agreed with the statement that performance was measured against the productivity (Mean=4.01, std.dev=1.31). Further

results showed that majority of the respondents who were 73.9% agreed with the statement that employees show a lot of concern of seeing that they complete their day's work (Mean=4.01, std.dev=1.31). Further results showed that most of the respondents who were 61.7% agreed with the statement that employees perform competently without pressure from their bosses (Mean=3.75, std.dev=1.25). In addition, results showed that most of the respondents who were 58.8% agreed with the statement that they are expected to have more individual responsibility for their job performance (Mean=3.75, std.dev=1.25). Further results showed that most of the respondents who were 71.9% agreed with the statement that employees perform competently without pressure from their bosses (Mean=3.83, std.dev=1.21).

Further results showed that most of the respondents who were 75.9% agreed with the statement that people are flexible and adaptable when changes are necessary (Mean=4.00, std.dev=1.29). In addition, results showed that most of the respondents who were 75.2% agreed with the statement that employee believe they can influence or affect their work place through their ideas and involvement (Mean=4.13, std.dev=1.15). In addition, results showed that most of the respondents who were 76.5% agreed with the statement that individuals and teams had clearly defined goals that relate to the goals or mission of the College. (Mean=4.00, std.dev=1.13). Further results showed that most of the respondents who were 72.5% agreed with the statement that they constantly stretched their goals, to continuously improve (Mean=3.89, std.dev=1.36). In addition, results showed that most of the respondents who were 70.1% agreed with the statement that people know what was expected of them and understand their impact on other people, teams, and functions (Mean=3.80, std.dev=1.27).

Further results showed that most of the respondents who were 65.1% agreed with the statement that people believe in teamwork, the "what's in it for us" approach rather than "what's in it for me." (Mean=3.55, std.dev=1.27). Results also showed that most of the respondents who were 65.1% agreed with the statement that managers at all levels work together as a team to achieve results for the University (Mean=3.77, std.dev=1.28). Further results showed that most of the respondents who were 56.7% agreed with the statement that they would be happy to spend the rest of their career in the University (Mean=3.69, std.dev=1.32). Results also showed that most of the respondents who were 65.4% agreed with the statement that managers at all levels work together as a team to achieve results for the University (Mean=3.56, std.dev=1.46). Further results showed that most of the respondents who were 71.1% agreed with the statement that work overtime to complete their tasks (Mean=3.87, std.dev=1.22).

### Regression Results

Regression analysis was used to examine whether compressed work schedule can be used to explain employee performance in public universities in Mt. Kenya region. The results presented in Table 8 presents the appropriateness of model used for the regression analysis in explaining the study phenomena.

**Table 8: Model of Fitness**

Model	R	R Square	Adjusted R Square	Std. Error of the Estimate
1	.877a	0.768	0.766	0.4377

The value of R was 0.877 and this implied that there was a positive correlation between job sharing and employee performance in public universities. In addition, job sharing was seen to be good enough to explain employee performance in public universities. This is supported by R<sup>2</sup> of 0.768. This means that the model fitness found out that job sharing explains 76.8 % of the variations in the dependent variable (all other factors held constant) which is employee performance in public universities.

### Regression Analysis

**Table 9: Regression of Coefficient**

	Unstandardized Coefficients		Standardized Coefficients	t	Sig.
	B	Std. Error	Beta		
(Constant)	-0.111	0.128		-0.867	0.387
Compressed work schedule	0.391	0.039	0.38	9.972	0.000

The results revealed that compressed work schedules and employee performance of public universities were positively and significantly related ( $\beta=0.391$ ,  $p=0.000$ ). This implied that an improvement in compressed work schedule by one unit would lead to improvement in employee performance of public universities by 0.391 units. The study findings agreed with Njiru (2016) who revealed that compressed work hours influenced employee performance, job satisfaction and enhanced staff morale

### Hypothesis testing

The null hypothesis ( $H_{03}$ ) was that there is no statistically significant relationship between compressed work schedules and employee performance of public universities in Mount Kenya region. Results showed that the t calculated of compressed work schedules was 9.972 which was greater than t critical (3.96). Therefore null hypothesis was rejected and the study concluded that there was a statistically significant relationship between compressed work schedules and employee performance of public universities in Mount Kenya region. The study findings agreed with Deery (2017) who indicated that compressed work week was a predictor of employee's performance.

#### Hypothesis 1

There is no statistically significant relationship between compressed work schedule and employee performance of public universities in Mount Kenya region.	Reject $H_0$ if $t_{cal} < t_{critical}$ (3.96)	9.172	The null hypothesis was <b>rejected.</b>
--	---	-------	--

### Summary

#### Compressed Work Schedules and Employee Performance of Public Universities

The third objective was to evaluate the extent to which compressed work schedules affects performance of Public Universities in Mount Kenya region. Results showed that majority of the respondents agreed with the statement that their job was compressed and in line with their interests, skills and attitudes. Further results showed that most of the respondents agreed that compressed



work week had improved their work in general. In addition, results showed that majority of the respondents agreed with the statement that they felt that service to customer was affected if staffs work through compressed schedules. Further results showed that most of the respondents agreed that they had high commitment to go to work through the implementation of compressed work schedules. In addition, results showed that majority of the respondents agreed with the statement that their motivation level at work could be increased through compressed work schedules. Further results showed that most of the respondents agreed that they usually took time to follow up with clients to ensure that they were satisfied with their services.

In addition, results showed that majority of the respondents agreed with the statement that compressed work schedules increased cost effectiveness and efficiency. Further results showed that majority of the respondents agreed with the statement that compressed work week was administered effectively. Further results showed that majority of the respondents agreed with the statement that compressed work schedules reduced employee turnover. In addition, results showed that majority of the respondents agreed with the statement that compressed work schedules had an influence on employee performance.

Regression results showed that compressed work schedules and employee performance of public universities were positively and significantly related. Hypothesis results showed that there was a statistically significant relationship between compressed work schedules and employee performance of public universities in Mount Kenya region.

The study concluded that there was a statistically significant relationship between compressed work schedules and employee performance of public universities in Mount Kenya region. The study also concluded that compressed work week helped to improve the work of employees in general. Compressed work schedules also improved the motivation level of employees as well as helped to improve the commitment of workers. The study also concluded that compressed work schedules reduced employee turnover.

### **Recommendations**

Managers should improve the use of flextime work arrangement because it enhances employee performance, reduces absenteeism and increases employee satisfaction. Universities should also build flexible arrangements since they help employees in managing their work load, their personal life and help them to assess their responsibilities

The study found that compressed work schedules had a positive and significant effect on employee performance of public universities was positively and significantly related. The study therefore recommends that universities should adopt favorable compressed work schedules since it enhance employee's commitment to organization goals, enable them to attend to family responsibilities better and is related to improved performance ratings.

In addition, this study focused on universities in Kenya and thus a similar study could be done in other countries such as Uganda, Tanzania. Since the R square was not 100%, it might imply that other additional parameters that can be considered in the measurement of flexible working arrangements such as shift working arrangements, part time working, temporary contracts and flexi time that could enhance employee performance in public universities in Mt. Kenya region.

## REFERENCES

- Austin-E., Et al (2020). Flexible working arrangements and organizational performance: An overview. IOSR
- Ayeni, Et. Al. (2007). Work Motivation, Job Satisfaction and Organizational Commitment of library personnel in academic and research libraries in Oyo State. Library philosophy and practice 1-16.
- Bhusan, B., & Sar, A. K. (2020). Critically analysing the concept of workplace flexibility and how it impacts employee and organizational performance: A case of the retail industry in India. Eurasian Chemical Communications, 2(9), 1001-1010.
- Forgasz, Et- al (2006). Academic life: Monitoring work patterns. The Australian educational researcher 33(1): 1- 22.
- Hill, E., Et. Al (2010). Finding an extra day, a week: The positive influence of perceived job flexibility on work and family life balance. Family Relations, 50, pp.49-50.
- Jane, M., Et al (2015). Effect of flexibility in work arrangements programs on job satisfaction of nurses in public hospitals in Nakuru County, Kenya. Unpublished Research, Nairobi, Kenya.
- Karamanis, K., & Gogos, C. (2020). The impact of flexible working at firm level. Evidence from Greek labor market. Journal of International Studies, 13(2).
- Kothari, C.R. (2010). Research Methodology- Methods and Techniques, (2nd Ed.). New Delhi: New Age International Publishers.
- Lutz, J. D. (2012). Alternative Work Arrangements: An examination of job sharing, compressed workweeks, and flextime. xvii. Mayer AL & Tikka PM (2008) Family-friendly policies and gender bias in academia. Journal of Higher Education Policy and Management 30(4): 363-374.
- Meyer, P., Et al (2002). Affective, continuance, and normative commitment to the organization: A meta-analysis of antecedents, correlates, and consequences. Journal of Vocational Behavior, 61, pp.20-52
- Meyer, J., & Allen, N. (1997). Commitment in the workplace. Thousand Oaks, CA: SAGE Publications.
- Mitchell, M. L., & Jolley, J. M. (2012). Research design explained. Cengage Learning xxi.
- Mungania, A. Et Al. (2016). Influence of flexible work arrangements on performance of the banking industry in Kenya. International Journal of Academic Research in Business and Social Sciences. Vol. 6, No. 7 ISSN: 2222-6990.
- Njiru, P. M. (2013). The influence of flexible work practices on employee performance in public sector: a case of ministry of interior and coordination of national government, Embu County (Doctoral dissertation, Karatina University).
- Reilly, P, (2009). How will HR weather the storm of 2009? Personnel Today p.14.

- Rooplal, M. (2017). South African Perspective on the Implementation of Flexible Work Practices (Doctoral dissertation), The IIE.
- Saunders, M.N.K. & Townsend, K. (2018). Choosing participants. In C. Cassell, A. Cunliffe, & G. Grandy (Eds.). Sage handbook of qualitative business and management research methods (pp. 480–494). London: Sage.
- Small, K. (2008). Relationships and reciprocity in student and academic services. *Journal of Higher Education Policy and Management* 30(2): 175-185.
- Williamson, S. et. Al. (2015). Job-sharing among teachers: Positive, negative (and unintended) consequences. *The Economic and Labour Relations*
- Oliver, R. (1974). Expectancy Theory Predictions of Salesmen's Performance. *Journal of Marketing Research* 11(3), pp. 243-25
- Omondi, A. et. Al (2018). Flexible work schedules: A critical review of literature. *The Strategic Journal of Business & Change Management*, 5(4), 2069 - 2086.
- Romzek, B. (1990). Employee investment and commitment: The ties that bind. *Public Administration Review*, 50, 374-382. xxxii. Sadri, G. et. al. (2011). Meeting employee requirements: Maslow's hierarchy of needs is still a reliable guide to motivating staff. *Industrial engineer*, 43(10), 44-49.
- UNICEF 2019 on Guidance for employers on flexible work arrangements, childcare support and other good workplace practices in the context of COVID-1