

International Journal of Technology and Systems (IJTS)

**A SURVEY PAPER ON AUTOMATED ELECTRONIC
TOLLING SYSTEMS USING RADIO FREQUENCY
IDENTIFICATION TECHNOLOGY**

Misheck Phiri and Lincoln Nhapi



A SURVEY PAPER ON AUTOMATED ELECTRONIC TOLLING SYSTEMS USING RADIO FREQUENCY IDENTIFICATION TECHNOLOGY

^{1*}Misheck Phiri

Post graduate student: Cloud computing: Harare institute of Technology

phiri@hrepoly.ac.zw

²Lincoln Nhapi

Lecturer, School of Computer Science: Harare Institute of Technology Zimbabwe

lbnhapi@gmail.com

Abstract

Purpose: In this paper we carry out a review on Automated e-tolling systems using RFID technology that has already been proposed by other researchers. Analysed and synthesised the researchers' solutions and identifying their advantages and disadvantages, and also the gap they left that needs further research.

Methodology: the approach used to conduct this review was to collect extensive peer reviewed literature on how solutions by several authors' RFID technology implementation for Automated e-tolling systems helped collect road tax automatically and efficiently around the world with the effect of eliminating vehicle congestion around toll plazas. A prototype was developed to test the effectiveness of our proposed solution.

Findings: This study found out that the use of RFID technology in Automated E-tolling systems is the cheapest and most effective way of collecting road tax revenue without delaying motor vehicles. Furthermore, enables vehicles to pay road tax while moving. This study also revealed that for the Automated E-tolling system to be secure and efficient the communication between RFID tag and reader has to be secured. Due to limitations in resources in cheap passive RFID tags, text steganography using Unicode zero width characters is most appropriate due to its high embedding capacity and very low processing needed.

Unique contribution to theory, practice and policy: The review was able to bring out the importance of securing the communication between tag and reader thus building a system with security from design not as an afterthought. It also reveals the use of text steganography as a way of preserving tag privacy. Vehicle congestion at toll collection points has a domino effect of causing pollution to the environment, loss of productive time while waiting in the queue at toll plazas to be saved and also loss of fuel while the vehicle is idling waiting for its turn to be saved. Automated e-tolling systems using RFID technology also reduces the cost of collecting road taxes by significantly reducing the manpower needed at various toll plazas thereby making the system more efficient than the current manual or semi-automated toll collection systems currently available in Zimbabwe.

Key words: *RFID, cloud computing, steganography, privacy.*

INTRODUCTION

This research targets the road users and the road tax collector, Zimbabwe National Roads Administration (ZINARA) Toll collection is a method used in many countries to collect money for road usage which will help in repairing and construction of other roads. The first automated e-tolling system was first introduced and implemented in Trondheim in Norway in 1991 (Polavarapu et al., 2018). Techniques that enable efficient collection of this revenue without negatively affecting the road users, the road administrators and the environment are implemented. RFID vehicle identification technology has proved very efficient and cheap as compared to various vehicle identification technologies such as Automatic Number Plate Recognition (ANPR) usually known as Video tolling, Dedicated Short Range Communications (DSRC) technology, Global Navigation Satellite Systems (GNSS) technology and Tachograph-based technology. RFID is widely used in various sectors in the world, manufacturing, medicine, agriculture, security, warehouses etc. (Jung & Lee, 2015). The automated e-tolling system will clear vehicle congestion at Zimbabwean toll gates as vehicles will not need to stop at toll gates in order to manually pay toll fees. This will also reduce pollution and fuel wastage as is the case with available manual tolling systems in Zimbabwe. This proposed e-tolling system will automatically collect toll on moving vehicles that pass through the toll gate. The problem of RFID tag tracking used by criminals to track cars that pass through different toll gates for purposes of either stealing them or stealing the cargo that they will be carrying. This paper proposes a modified text steganography technique to hide actual data that is communicated between RFID reader and RFID tag such that tracking of tags will be extremely difficult if nearly not impossible. Currently Zimbabwe uses manual toll collection systems where a vehicle has to stop at the toll plaza and make payment either electronically or manually so that it can pass through. The current manual system though uses weight of the vehicle to classify the vehicle in order to determine the correct fee that a vehicle has to pay and this is done when the car is registered and the information will be stored in the database. This manual system causes congestion at the toll plaza which is sometimes unbearable during festive seasons and other public holidays. The current system also enables revenue leakages and environmental pollution, wastage of fuel while waiting in the queue. According to A. Chilunjika (Nelson & Rose, 2018) revenue from Zimbabwean toll gates rose by 80% when electronic payment systems were introduced at toll gates as compared to manual methods where only cash was the accepted mode of payment. The proposed solution will significantly improve revenue collection as it will minimise the costs of revenue collection by significantly reducing manpower at toll gates and also minimising revenue leakages.

PROBLEM STATEMENT

Road tolling has proven to be a good source of revenue collection for road maintenance and building of new roads. Since the introduction of toll gates in Zimbabwe, vehicles now spend a lot of time at toll gates trying to pay toll fees leading to a perennial problem of vehicle congestion near toll plazas. Traffic congestion has a domino effect in that it causes air pollution, fuel wastage, road accidents, revenue leakages in that vehicle users will find ways to avoid going through these toll plazas because of the delays that they cause to travellers. The Current E-tolling system has not managed to solve the congestion problem because every vehicle has to stop at the toll plaza so as to make payment electronically and sometimes with physical cash. Vehicle congestion at toll plazas has a domino effect of causing a lot of pollution to the environment as alluded by Ching-Huang Lai (Lai et al., 2021). The mentioned problem above led to the following question, "How can road tax revenue be

collected effectively at various toll plazas in Zimbabwe without causing delays to travelling road users?

JUSTIFICATION OF THE STUDY

Questionnaires were sent to various groups of road users to get their views on the use of toll plazas. Stratified random sampling was used on distributing the questionnaires. The strata were composed of bus drivers who passes through the toll plazas on a daily basis, commuter taxi drivers, ordinary vehicle owners and tollgate booth operators(cashiers). Seven toll plazas were targeted out of a total of thirteen. Observations were done also on the seven toll plazas. Data obtained from all these data gathering techniques revealed that 98% were not happy with the delays they usually experience on various toll plazas. So a research was necessary to find a solution on how best to solve the problem.

RELATED WORK

IL.D Vijay Anand(Anand & Hepsiba.D, 2017) proposed system uses RFID for vehicle identification and uses weight measured by a load cell at the toll plaza to classify the vehicle to determine how much it should pay. Weighing vehicles at the toll plaza slows down processes as load cell is not very good at weighing fast moving objects such that vehicles are supposed to first stop which will eventually lead to congestion around the toll plaza.

Raed Abdulla(Abdulla et al., 2018) proposed an e-tolling system that uses RFID for vehicle identification. The system uses ultrasonic sensors to classify vehicles using height and the gate is always open for vehicles to pass and only closes when there is a violation. Ultrasonic sensors are most suitably used as proximity sensors and can produce unpredictable results when used to calculate height of vehicles. They compromise precision and accuracy of the results.

Sai Sharan Chandragupta(Sharan, 2019)proposed an e-tolling system that uses RFID technology for vehicle identification where the unique id read from the tag is sent to a central server where amount deduction is carried out. The system also checks whether the vehicle is on the stolen list in order to notify the respective authorities to take action. The system also checks whether the vehicle is overloaded using load sensors so as to add an extra charge. The system uses, Arduino MEGA 2560 as the microcontroller, infrared Sensor for sensing a passing vehicle to determine when to close the gate, Load cell for weight measurement, Image processing with Camera for theft detection. Its databases are hosted on the cloud. The researcher does not specify what type of tag he uses. No user feedback from the system. However, the researcher brings in an important aspect of automatically closing the gate after the vehicle has passed through.

Sabbir Ahamad proposed a system in which an RFID reader will read the RFID tags that are mounted on vehicles and the system will automatically deduct a specific amount of toll from the scanned tag id with the help of the database(S. Ahmed et al., 2019).

Shridevi. Soma (Soma, 2019) the proposed system uses RFID for vehicle identification and uses distance covered for classification. This classification method is not suitable for the Zimbabwean scenario because ZINARA does not classify vehicles using distance but vehicle mass.

B. Kommey (Kommey, 2020) proposed an electronic tollbooth collection and management system suitable for developing countries, especially for Ghana in this context. The proposed system uses Radio Frequency Identification (RFID) tags and uses them to identify a

particular user's account that has been registered in the system(Kommey, 2020). This unique identity read by the RFID reader is passed on to the microcontroller unit responsible for processing the data and transmitting it wirelessly to an online server that hosts the users database and the system that identifies the account the unique ID is associated with and handling deductions from the specified user's account. Feedback from this process is sent back to the microcontroller unit so the user receives a response with details of the transaction that would have been done. Uses GSM (GSM shield) to connect to the internet, uses TDMA for tag anti-collision, uses a database hosted on the cloud (Hiroku) the researcher implements anti tag collision which makes his proposed system more efficient because in times of heavy traffic there will be very minimum tag misses for the reader.

K. Devi Priyanka(Priyanka et al., 2020) proposed system uses RFID for identification. It also uses near field communication such that the user has to bring the card nearest to the reader which causes the vehicle to somehow stop and bring the card near the reader to be read. The solution will not totally eliminate congestion.

Md.Armanul Hagu(Hagu et al., 2020)proposed an automated toll collection system that uses RFID technology and a GSM module. Their key aspect being automatic deduction of money from vehicle owners maintained account without the vehicle stopping. Their proposed model being formulated by RFID and GSM modules that are controlled by a microcontroller based database control module. Their proposed system also uses IR sensor to determine when to open or close the gate. The authors use experimentation Methodology to test and prove their hypothesis. They produced a prototype using the following components:MG90S servo motor, SIM908-C GSM modem, photoelectric proximity sensor, microcontroller(PIC16F877A), LCD display and RFID tag and RFID reader from their experimental results they concluded that it will take just 30 seconds for a vehicle to pass through the tollgate. Their methodology is clearly stipulated in their paper and the methods used are clear and concise. Their proposed solution makes sure that there is no congestion in that there is an alternative pathway for vehicles with insufficient balance in their accounts and those without tags to manually pay without obstructing the flow of traffic. The only drawback about the proposal is that the authors do not address the issue of tag privacy and tag collision.

M A Berlin et al, 2020 proposed a system that has roadside units stationed 250m before and away from the toll plaza(Berlin et al., 2021). These roadside units query the vehicle whether it is registered or has enough balance in its account for payment. If not an alert message is sent to warn the vehicle owner to recharge his account before entering the toll plaza. The system is gateless and also has a violation module that detects and reports payment violators to responsible authorities to take action against such violations. Their system uses RFID technology for vehicle identification. The authors ideas are good but not applicable in the Zimbabwe because in Zimbabwe it will not be good idea to have a gateless toll plaza.

Kavyashree (Kavyashree et al., 2020) proposed a system that uses RFID for identification and all the vehicle details will be stored on the tag. This is not a secure way of implementing because anyone with a reader that uses that frequency can easily view all the details of the car and be able to track it. A sensor is used to detect the presence of a vehicle. A prototype is also build to test the concept.

Piyush Sinhal(Et. al., 2021) proposed a system that uses RFID for vehicle identification classification of the vehicle is done by camera first taking photo of the number plate and comparing the details with what is in the database. This system uses relays for opening and

closing the toll barrier. This shows a big flaw in design since relays are not reliable as drivers of gates and also the researchers references are out of context with the subject of study.

Md Namzul (Mir et al., 2021) proposed a solution that uses RFID for vehicle identification and reading data. A prototype is constructed to test functionality of the concept. This proposed solution only reduces congestion but does not completely eliminate it since the vehicle has to first stop because near field communication is being used.

Nimritee Sirsalewala (Sirsalewala et al., 2021) proposed a barrier less e-tolling system that also keeps record of every vehicle that passes through the toll plaza. This system that has no barrier cannot be implemented in Zimbabwe due to the lawlessness of road users in Zimbabwe.

Hanguang Luo(Luo et al., 2016)proposed an RFID systems authentication protocol SLAP(succinct and lightweight Authentication Protocol) that secures the system against attacks such as desynchronization attack, replay attack and traceability attack. This solution does not guard against all the RFID systems authentication attacks so further research has to be done to find the optimum solution.

Han Shen(Shen et al., 2017) in their paper highlighted security weaknesses of previously proposed RFID authentication schemes and proposed their own RFID authentication scheme using elliptic curve cryptography(ECC). The researchers highlight that by default the insecure part of the system is the communication between RFID reader and RFID tag. The researchers go on to compare Chan et al's scheme and Ryu et al schemes to their proposed scheme where they discovered through experimentation that for mutual authentication, anonymity, confidentiality, untraceability, forward security, and attack protection. Chan et al falls short on attack protection and Ryu et al falls short on mutual authentication. However, the proposed ECC does not protect against all possible RFID systems attacks.

Atul Kumar (Kumar et al., 2021) highlighted security issues that are faced by RFID systems ,classifying them into different categories and offering various solutions that were proposed by various researchers . the authors touch on issues to do with privacy, forward security and authentication. Atul Kumar et al concluded that further improvements on security issues that affect RFID systems need to be done until one solution is found that solves all these security issues associated with RFID systems.

All researchers referenced above proposed systems that minimises congestion near toll plazas but all their systems do not preserve tag privacy that lead to the problem of tag tracking by criminals.

Table 1.

ANALYSIS OF THE LITERATURE USED ON RFID BASED AUTOMATED TOLL COLLECTION SYSTEMS

Table below shows an analysis of the literature used on RFID based automated toll collection systems implementations proposed by referenced authors in this paper

Authors	Method used	Advantages	disadvantages
L.D Vijay Anand (Anand & Hepsiba.D, 2017)	-uses RFID for vehicle identification -uses load cell for classification by measuring weight	none	-The paper does not contain literature review section -used methodology not clear -no results are displayed -Weighing at the toll plaza introduces a delay that leads to congestion
K Brindha Devi (Devi et al., 2017)	-uses RFID for vehicle identification -warning sent to user if balance is insufficient	-uses IR sensor to detect the presence of a vehicle at the toll plaza -design is clearly shown by a block diagram -method and tolls to be used are clearly listed and stated.	-not allowing vehicles with insufficient balance and without tags without offering them an alternative pathway to follow will create congestion
Raed Abdulla(Abdulla et al., 2018)	-uses RFID for vehicle identification -gate always open by default and closes when there is a violation -uses ultrasonic sensors to measure height in order to classify vehicles	-evaluation of the produced results from testing is clearly stated	-in Zimbabwe height cannot be used for vehicle classification but weight -pay later method cannot be used in Zimbabwe because of lawlessness -closing of the gate for toll violators can cause accidents
Sushma Chowdary Polavararapu (Polavarapu et al., 2018)	-uses RFID for vehicle identification -uses tag unique ID to identify the vehicle details on the remote database	-clearly lists the tools to be used .	-the paper does not have any reviewed literature section -results are not shown that show proof that the concept works
Shridevi Soma(Soma, 2019)	-uses RFID to identify vehicles -also measures how much pollution the vehicle is causing -cost is calculated as per distance covered	-The amount is charged as per distance covered	-the system uses near field communication and cannot eliminate congestion as the vehicle needs to stop first to make payment -using delay on when to close the gate is not proper instead sensors should be used.
Sabbir Ahmed(S. Ahmed et al., 2019)	-Uses RFID for identification	-clearly stipulates the tools used	It is not secure to put all vehicle details on the tag

	-all vehicle data is stored on the tag	implement the system	Methodology is not clearly stipulated -no clear showing of results -there is no communication between user and system
Sai Sharan (Sharan, 2019)	-uses RFID for identification -uses weight for vehicle classification -weight is measured at the toll plaza using load cell -monitoring of vehicles is done using image processing	-uses a unique tag id to link with user details on the database hosted on a server	-methods used are not clearly stated -no results are shown after testing
Benjamin Kommey(Kommey, 2020)	-Barrier less, uses RFID for identification and GSM for communication with user. -uses a prototype for testing the functionality of the system	-there is a sensor to detect the presence of a vehicle -uses TDM protocol to guard against tag collision -there is communication with the user in the form of sms	-The authors do not specify which microcontroller he uses on the prototype -a gateless toll system is not applicable in Zimbabwe due to lawlessness
M.d Armanulu(Haque et al., 2020)	-uses RFID and GSM Deducts money from the user's account automatically -a vehicle doesn't need to stop -uses a barrier -uses a prototype to test concept	-communicates with the users through sms -the implementation makes sure congestion does not occur by providing an alternative pathway for vehicles with insufficient balances and without tags -clearly specifies the components used to build the prototype -results are clearly stipulated showing a big increase on vehicles served on the toll plaza as compared to manual system	-no sensor to detect the presence of a vehicle approaching the toll plaza
Kavyashree M.(Kavyashree et al., 2020)	-uses a sensor to detect the presence	-Uses a sensor to detect the presence	-uses a delay to close the gate instead of a sensor.

	<p>of a vehicle at toll plaza. Uses RFID to identify a vehicle -all vehicle information is stored on the Tag Uses IR sensor for accident detection</p>	<p>of a vehicle at toll plaza</p>	<p>-Results of the test are not shown. -the researcher at first used raspberry pi microcomputer but on his conclusion says Arduino microcontroller was used</p>
MA Berlin (Berlin et al., 2021)	<p>-uses a barrier less system -uses RFID for vehicle identification -no humans man the toll plaza -RSU (road side unit) are used to process payment decision and payment violation -RSU also interacts with the database -RSU also used to control a vehicle's fuel transmission system -RSUs also used to query the database to check whether the vehicle has paid or not.</p>	<p>-the system ensures that zero congestion occurs at the toll plaza -results of the study are well presented and easy to interpret RSUs are used to cut a vehicle's fuel transmission system that is in violation of payment 250m away from the toll plaza</p>	<p>-Cars without computer boxes (old cars) cannot be stopped by such a system</p>
M d. Nazmul Hossain Mir (Mir et al., 2021)	<p>Uses RFID to identify vehicles. Uses a sensor to detect the presence of a vehicle in the toll plaza</p>	<p>-uses a sensor to detect the presence of a vehicle in the toll plaza</p>	<p>-by recharging account at toll plaza introduces delay -methods used are flawed as shown by the results -results shown are unrealistic as compared to what many researchers produced five seconds as compared to fifteen to thirty seconds.</p>
(Srivastava, 2021)	<p>Does a review of the usefulness of RFID in e-tolls in Bangladesh</p>	<p>Evaluates the popularity of different e-toll cards using a mathematical formula</p>	<p>-only highlights the importance of e-tolls in Bangladesh -dwells mainly on the popularity of certain e-toll cards brands.</p>
Nimritee Sirsalewala(Sirsalewala et al., 2021)	<p>-The system does not have any barrier. -Keeps track of all vehicles that pass through. Has a report generation module that keeps track of all transactions done at toll plaza -all vehicle</p>		<p>-method used is not clearly stated and difficult to follow -gates without barriers are not suitable for Zimbabwe -no results are displayed to show that the system works -no experiments were done to prove that the idea works -the paper omitted literature review</p>

	information is stored on the RFID tag -ANPR is used to store images and text from licence plate and sometimes takes images of the driver		
Soundhyra (B M et al., 2021)	Proposed a solution that uses FRID technology for identification and locating and tracking stolen vehicles	-uses gps to track stolen vehicles	-there is no mechanism to detect the presence of the vehicle such that power is wasted on the reader which will in continuous scanning mode
(Mir et al., 2021)	-proposed a solution that uses Artificial intelligence and RFID technology for E-tolling	-The model records the vehicle details and the driver's details	-stopping vehicles that do not meet requirements without suggesting an alternative route for them tends to create further delays that will lead to congestion
Piyush Singal (Et. al., 2021)	-RFID technology is used for vehicle identification -uses relays to open and close the gate -unique ID is used to find the vehicle details in the database -the system comprises two units, mobile unit placed on the vehicle and stationery control unit that is mounted on the toll road	-results of the experiments are clearly shown	-relays are not reliable when used for opening and closing of the gate because due to arcing they quickly fail. -Not opening the gate for violators without offering an alternative pathway to follow will lead to congestion at the toll plaza

Table 2:ANALYSIS OF PAPERS ON RFID SYSTEMS SECURITY

Authors	Method used	Advantages	Disadvantages
Hanguang Luo (Luo et al., 2016)	-composed of bitwise XOR operations and conversion -an authentication protocol	-less computation requirements -Easy to implement on passive tags	- for XOR encryption long runs for the same characters easily exposes the hidden message
Han Shen (Shen et al., 2017)	-Uses elliptic curve cryptography. -	-works well on active expensive tags	-heavy computation involved so not suitable for low cost passive tags

Salwa Shakir Baawi(Baawi et al., 2018)	-Enhancement of Text Steganography Technique Using Lempel-Ziv-Welch Algorithm and Two-Letter Word Technique	-can hide 4 bits in each position of a two-letter word in the cover text by inserting a nonprinting Unicode symbol -high imperceptibility	-Low embedding capacity
Hamidreza Damghani (Damghani et al., 2019)	-uses the security bit method(a logical bit embedded in RFID tag)	-suitable for inventory systems	-not suitable for use on vehicle identification
Janakiraman,(Janakiraman et al., 2019)	-proposed an indicator based lightweight LSB(least significant bit) steganographic compared to its device dependent implementation aspect with similar algorithms on RISC microcontrollers.	-used sample pair staganalysis to test the security of the algorithm -suitable for resource constrained RFID components	-the algorithm has low embedding capacity.
Hafsat Muhammad Bashir (Baawi et al., 2018)	-uses text steganography for hiding information -uses Unicode zero-width characters	-less computation -high embedding capacity and very robust -high invisibility against visual attacks	-one time pad cryptography
Alfin Naharuddin(Naharuddin et al., 2018)	-proposed a secret text embedding method in cover text mapping, secret text binary digit onto binary digit of cover text using ASCII characters involving spaces, punctuation, and symbols	-high imperceability	-very low embedding capacity because one secret text character requires seven carrier text characters. -one time pad encryption is not secure
K. Joshi(Joshi, 2018)	-the approach is based on combining the character's ASCII with the RGB values of a pixel.	-easy to implement because colours have better embedding capacity as compared to text	-cannot be used on resource constrained gadgets such as passive tags

		to text	
Yongju Tong (Tong et al., 2019)	-Recurrent Neural Network (RNN) Encoder-Decoder model to generate Chinese pop music lyrics to hide secret information	-high embedding capacity -secure	-Not suitable for resource constrained passive RFID tags because the solution requires more memory
(Wu et al., 2019)	-proposed a coverless text steganography method based on Markov chain model	-Good imperceptibility	-high computation required
NingWu(Wu et al., 2020)	- proposed a new text steganography approach that focuses on transition probability	- this method can avoid steganalysis based on statistical features better than other methods	-carrier less steganography techniques usually have very low imperceptibility
Rafael Mezzari(Mezzari, 2020)	Proposed a text steganography using reserved bit to hide information in a Tag	Less computation	-Very low embedding capacity -Not very secure
Anandapra Majumder (Goyal & Kar, 2020)	-A New Text Steganography Method Based on Sudoku Puzzle Generation	-high imperceptibility -secure	-low embedding capacity
Majeed(Majeed et al., 2021)	-a review on various text steganography techniques	-quite comprehensive and well structured	-only highlights the advantages of each text steganography technique used and does not state the drawbacks of each proposed technique.
Atul Kumar (Kumar et al., 2021)	-highlights RFID security issues and proposed mitigatory measures	-comprehensive and well structured	-due to limitations in resources most proposed lightweight cryptographic schemes cannot be applied on cheap passive tags
Cesar Munoz-Ausecha(Munoz-ausecha et al., 2021)	-RFID applications and security review	-comprehensive -describes the most active topics of investigation regarding RFID technology	-although does not offer solutions ,it offers various research gaps that can lead to various researches on RFID systems security
Yahya Khan (Khan et al., 2021)	-A double-secure algorithm for text	-suitable for short messages	-one time pad has a security flaw such that when run several

	steganography		times can reveal the hidden message
M. Imtyaz Ahmed (M. I. Ahmed & Kannan, 2021)	-Proposed a Secure and lightweight privacy preserving Internet of things integration for remote patient monitoring using RFID	-purports untraceability	-Proposed authentication scheme is prone to tag cloning - There is a high computational cost which is not suitable for passive RFID tags

PROPOSED SOLUTION

The proposed system will use RFID technology for vehicle identification but will use RFID readers and tags that are fully anti-collision compliant. They should operate in ultra-high frequency range(uhf) thereby offering a higher bandwidth and faster data transfer rates between reader and tag. We will adopt the current vehicle classification systems already available at toll gates in Zimbabwe that uses pre-recorded weight of vehicle as well as the Optical character reader cameras that are currently at the toll gates for violation enforcement. The system will use cloud authentication services for tag integrity and confidentiality. The system will have its database hosted on the cloud. As for privacy preservation between reader and tag steganography techniques will be used. Text steganography will be the best option considering the limitation in processing capabilities of the tag and also the limitation in the tag's memory

The components of the proposed automated solution will be as follows:

1. Automatic Vehicle Identification(AVI) –vehicles are automatically identified using RFID technology to determine who owns the vehicle, so that the toll amount is charged and deducted from the rightful owner's account.
2. Automatic Vehicle Classification- vehicles will be automatically classified using their weight recorded during registration and also type of vehicle. Different classes will have different toll fees that are supposed to be paid. The vehicle type may include light vehicles like the passenger car or heavy vehicles like recreational vehicles. A vehicle's class can be determined by the physical attributes of the vehicle. In this instance we will stick to what is currently used at manual toll plazas in Zimbabwe, which is a vehicle is classified according to its mass. Classification is done when the vehicle is registered at CVR and not at the toll plaza and the details entered into the cloud hosted database together with all the required vehicle details.
3. Payment – after the vehicle has been identified and classified an amount has to be deducted from the vehicle owner's account.
4. Video Enforcement system(VES)- the system (VES) captures images of the license plates of vehicles that pass through an electronic tollbooth without a valid RFID tag or insufficient balance. This system already exists at ZINARA toll plazas, it just needs to be adopted and integrated to the proposed automated toll collection system.
5. Securing the tag ID using text steganography that uses Unicode zero width characters to hide tag ID because of its high embedding capacity and low memory usage and low processing capacity needed.

Fig 1

proposed system flowchart

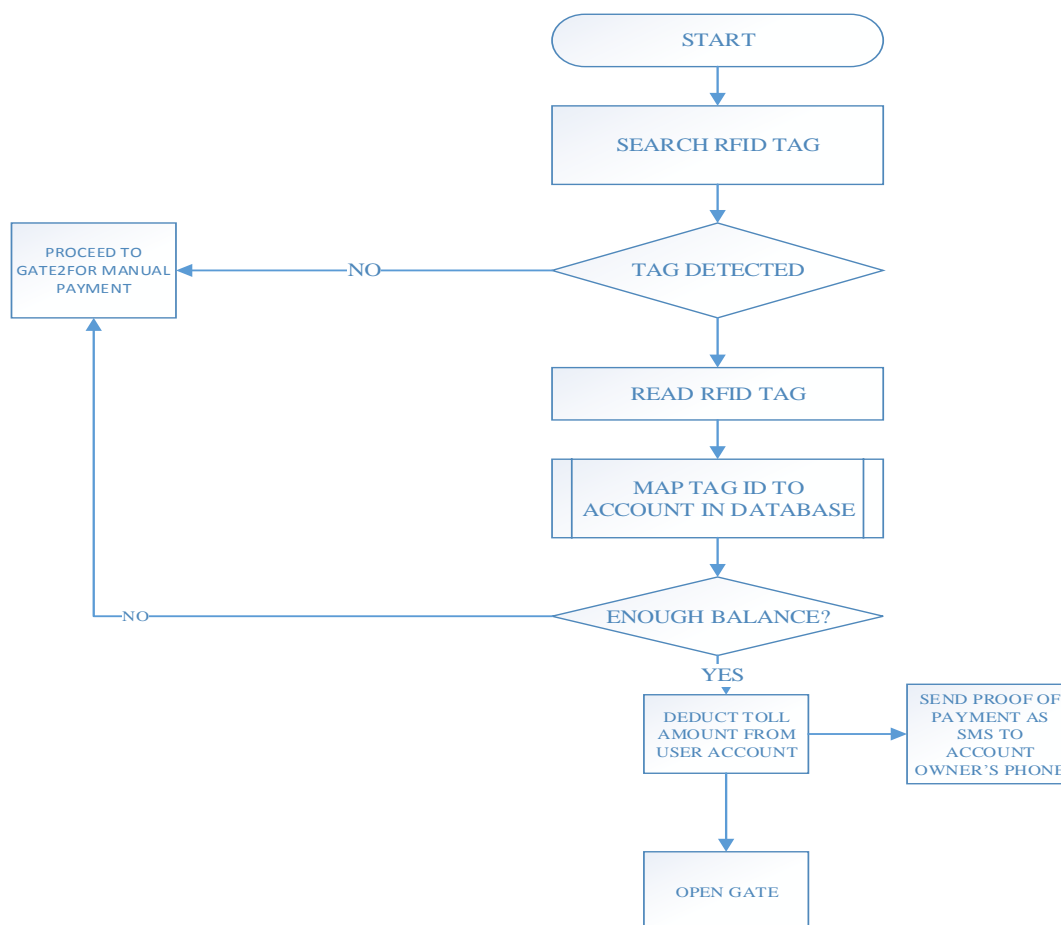

Proposed system flowchart

METHODOLOGY

Queuing theory using a single server model, infinite queue model and infinite population model was used to determine how efficient the service offered by our proposed solution will be.

A prototype was created to test the concept using the following materials:

1 Arduino Mega 2560/ Wi-Fi microcontroller: microcontroller is the heart that controls all operations to be carried out by the system. All components are connected to this microcontroller using specific pinouts.

2 ultrasonic HC-SR04 proximity sensor: In this prototype it is deployed as a proximity sensor to detect that an object has completely crossed the tollgate barrier and message is sent to microcontroller unit (MCU) so that an interrupt signal is sent to the servo motor to now close the barrier(gate).

3 micro servo motor SG90: It is used to open and close the barrier on the gate in this prototype, thereby controlling what should pass through and what should not.

4 IR flying fish MH8 sensor: In this prototype it is being deployed as an object detection sensor. In this scenario it detects the presence of a vehicle in the range of 10cm.

5 breadboard: It is used in this scenario to build the circuits for the prototype instead of using printed circuit boards that requires soldering components to the printed circuit board. Being used to connect different components to the MCU.

6 RC522 RFID reader: In this prototype it is used to read information (unique ID) from the RFID tag and pass it to the Arduino Mega 2560 MCU which is then send to the cloud using an on-board ESP8266 Wi-Fi module for authentication and checking if the account linked to the unique ID on the tag has the required balance to pay the toll fees. It's reading distance is 5cm. It uses the frequency range 13.56 MHz ISM band.

7 RFID tags: to store an ID that links the vehicle to its details on the database that is hosted in the cloud.

8 Arduino power supply 12v- 3A: This is used to supply power to the MCU using UART port that is on the MCU and also supplying power to different components that are connected to the MCU.

9. 16*2 LCD1602: In this prototype the liquid crystal display is used to display messages for the user such as “insufficient balance”, ‘tag not found “and “authorised”. It is a 16*2 LCD that means it can only display a maximum of 32 characters from the system.

10. Arduino IDE

Was used to write code for the embedded system using C programming language and was also used to upload the code to the MCU (Arduino mega 2560/Wi-Fi).

11. LARAVEL

It is a php framework which I used to create the system interface is used for registering vehicles. It is also the one that was used to code the text steganography utility for securing the communication between the reader and the tag.

12. MySQL

It is the database engine which I used to create the system database that is being hosted on the cloud.

Fig2.

Proposed system breadboard view

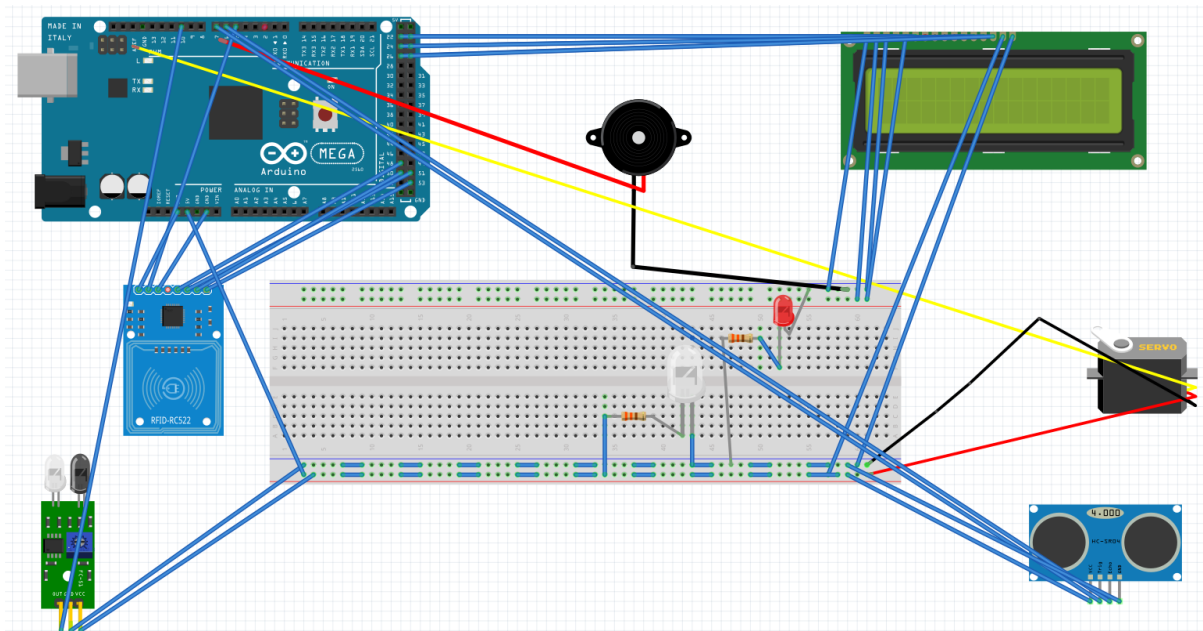

CONCLUSION

In this paper we analysed and synthesized what other researchers proposed as solutions to automate road toll collection systems using RFID technology. In our proposed system we incorporating security in design and implementation and not as an afterthought. RFID technology is being used for vehicle identification and need to be secured against all the mentioned possible RFID security attacks. Due to limitations in resources in RFID tags only lightweight to ultra-lightweight cryptography techniques are possible and they seem not to protect against all RFID systems attack. In this paper we suggest the use of steganography to solve these RFID system attacks. Furthermore, results obtained from testing the prototype showed that it only takes five seconds to complete all of the necessary processes at the toll plaza for a vehicle to pass through. There is a high chance that delays at toll plaza will never be experienced again.

RECOMMENDATIONS

According to data obtained from testing the prototype, quality of internet connection determines to a large extent the time it takes to complete all the processes on a toll plaza. We therefore recommend the use of fibre optic connections not wireless connections as they are still not reliable and are expensive in Zimbabwe.

References

Abdulla, R., Abdillahi, A. & Abbas, M. K. (2018). Electronic toll collection system based on

- radio frequency identification system. *International Journal of Electrical and Computer Engineering*, 8(3), 1602–1610. <https://doi.org/10.11591/ijece.v8i3.pp1602-1610>
- Ahmed, M. I. & Kannan, G. (2021). Secure and lightweight privacy preserving Internet of things integration for remote patient monitoring. *Journal of King Saud University - Computer and Information Sciences*, xxxx. <https://doi.org/10.1016/j.jksuci.2021.07.016>
- Ahmed, S., Tan, T. M., Mondol, A. M., Alam, Z., Nawal, N. & Uddin, J. (2019). Automated toll collection system based on RFID sensor. *Proceedings - International Carnahan Conference on Security Technology, 2019-October*, 1–3. <https://doi.org/10.1109/CCST.2019.8888429>
- Anand, L. D. V. & Hepsiba.D. (2017). Automated Highway Tollgate Collection System. *International Journal of Advanced Research in Education & Technology*, 4(2), 204–207.
- B M, S., R, Y., A D, T. K. & V, V. (2021). Automatic Check Post and E-Toll Payment System. *International Research Journal on Advanced Science Hub*, 3(Special Issue ICARD 3S), 57–62. <https://doi.org/10.47392/irjash.2021.064>
- Baawi, S. S., Mokhtar, M. R. & Sulaiman, R. (2018). A comparative study on the advancement of text steganography techniques in digital media. *ARPN Journal of Engineering and Applied Sciences*, 13(5), 1854–1863.
- Berlin, M. A., Selvakanmani, S., Umamaheswari, T. S., Jausmin, K. J. & Babu, S. (2021). Alert message based automated toll collection and payment violation management system using smart road side units. *Materials Today: Proceedings*, xxxx, 1–9. <https://doi.org/10.1016/j.matpr.2021.01.217>
- Damghani, H., Hosseinian, H. & Damghani, L. (2019). Investigating attacks to improve security and privacy in RFID systems using the security bit method. *2019 IEEE 5th Conference on Knowledge Based Engineering and Innovation, KBEI 2019*, 833–838. <https://doi.org/10.1109/KBEI.2019.8735043>
- Devi, K. B., Aruna, C., Meena, D., Ilamathi, M. & Priya, R. D. (2017). *Automatic Electronic Toll Collection System for Transportation by using Passive RFID Technology*. 1(1), 99–105.
- Et. al., P. S. (2021). RFID Based Vehicle Toll Collection System for Toll Roads. *Turkish Journal of Computer and Mathematics Education (TURCOMAT)*, 12(2), 2104–2113. <https://doi.org/10.17762/turcomat.v12i2.1815>
- Goyal, K. & Kar, A. K. (2020). Assessing Service Quality Factors in Mobile Payments - Insights Based on User Experiences in Social Media. In *Lecture Notes in Electrical Engineering* (Vol. 605). https://doi.org/10.1007/978-3-030-30577-2_66
- Haque, M. A., Shahid Iqbal, M. & Kabir, M. M. (2020). An Automated Toll Plaza System Using RFID and GSM Module: Perspective of Bangladesh. *2020 2nd International Conference on Sustainable Technologies for Industry 4.0, STI 2020*, 0, 19–20. <https://doi.org/10.1109/STI50764.2020.9350323>
- Janakiraman, S., Thenmozhi, K., Rayappan, J. B. B. & Amirtharajan, R. (2019). Indicator-based lightweight steganography on 32-bit RISC architectures for IoT security. *Multimedia Tools and Applications*, 78(22), 31485–31513. <https://doi.org/10.1007/s11042-019-07960-z>
- Joshi, K. (2018). A New Approach of Text Steganography Using ASCII Values.

- International Journal of Engineering Research & Technology*, 7(5), 490–493.
- Jung, K. & Lee, S. (2015). A systematic review of RFID applications and diffusion: Key areas and public policy issues. *Journal of Open Innovation: Technology, Market, and Complexity*, 1(1), 0–19. <https://doi.org/10.1186/s40852-015-0010-z>
- Kavyashree, M., Mamatha, M., Manasa, N. M., Vidhyashree, H. E. & Nagashree, R. N. (2020). *RFID Based Smart Toll Collection System*. 8(11), 177–180.
- Khan, Y., Algarni, A., Fayomi, A. & Almarashi, A. M. (2021). Disbursal of Text Steganography in the Space of Double-Secure Algorithm. *Mathematical Problems in Engineering*, 2021. <https://doi.org/10.1155/2021/7336474>
- Kommey, B. (2020). *GhanaToll: Barrier-Free RFID Toll Collection and Management System for GhanaToll: Barrier-Free RFID Toll Collection and Management System for Ghana*. June, 21–29. <https://doi.org/10.5120/ijca2020920278>
- Kumar, A., Jain, A. K. & Dua, M. (2021). A comprehensive taxonomy of security and privacy issues in RFID. *Complex & Intelligent Systems*, 7(3), 1327–1347. <https://doi.org/10.1007/s40747-021-00280-6>
- Lai, C. H., Hsiao, P. K., Yang, Y. T., Lin, S. M. & Candice Lung, S. C. (2021). Effects of the manual and electronic toll collection systems on the particulate pollutant levels on highways in Taiwan. *Atmospheric Pollution Research*, 12(3), 25–32. <https://doi.org/10.1016/j.apr.2021.01.020>
- Luo, H., Wen, G., Su, J. & Huang, Z. (2016). SLAP: Succinct and Lightweight Authentication Protocol for low-cost RFID system. *Wireless Networks*. <https://doi.org/10.1007/s11276-016-1323-y>
- Majeed, M. A., Sulaiman, R., Shukur, Z. & Hasan, M. K. (2021). A review on text steganography techniques. *Mathematics*, 9(21). <https://doi.org/10.3390/math9212829>
- Mezzari, R. (2020). *Using Steganography To Improve Confidentiality in Rfid Systems*. 1–8.
- Mir, M. N. H., Imrul Kayesh, N. M., Khan, T. M. & Sattar, A. (2021). IoT Based Digital Toll Collection System: A Perspective. *Proceedings - International Conference on Artificial Intelligence and Smart Systems, ICAIS 2021, 2016*, 1406–1410. <https://doi.org/10.1109/ICAIS50930.2021.9395996>
- Munoz-ausecha, C., Ruiz-rosero, J. & Ramirez-gonzalez, G. (2021). *RFID Applications and Security Review*.
- Naharuddin, A., Wibawa, A. D. & Sumpeno, S. (2018). A High Capacity and Imperceptible Text Steganography Using Binary Digit Mapping on ASCII Characters. *2018 International Seminar on Intelligent Technology and Its Applications (ISITIA)*, 287–292.
- Nelson, S. C. & Rose, J. D. (2018). *Smart and Innovative Trends in Next Generation Computing Technologies* (Vol. 827, Issue August). Springer Singapore. <https://doi.org/10.1007/978-981-10-8657-1>
- Polavarapu, S. C., Kunduru, U. & Nallamala, S. H. (2018). RFID based automatic tollgate collection. *International Journal of Engineering and Technology(UAE)*, 7(2), 1–5. <https://doi.org/10.14419/ijet.v7i2.1.9871>
- Priyanka, K. D., Durga, K. V., Anusha, V., Kumar, V. P. & Siva, S. (2020). *AUTOMATIC TOLL E-COLLECTING SYSTEM FOR TRANSPORTATION*. 06, 517–522.

- Sharan, S. (2019). *Automated road tolling system using RFID*. 5(2), 1778–1780.
- Shen, H., Shen, J. & Khurram, M. (2017). Efficient RFID Authentication Using Elliptic Curve Cryptography for the Internet of Things. *Wireless Personal Communications*, 96(4), 5253–5266. <https://doi.org/10.1007/s11277-016-3739-1>
- Sirsalewala, N., Bhosle, D., Narayan, S. & Jha, S. (2021). *Automated Toll Management System*. 542–544.
- Soma, S. (2019). *an Intelligent Toll-Gate System for Toll Collection Based on an Intelligent Toll-Gate System for Toll Collection Based on Distance and Pollution Control Using Internet*. January.
- Srivastava, S. (2021). *Radio Frequency Identification (RFID) Application Analysis on E-Toll in Indonesia* *Radio Frequency Identification (RFID) Application Analysis on E-Toll in Indonesia*. <https://doi.org/10.1088/1757-899X/1125/1/012050>
- Tong, Y., Liu, Y. L., Wang, J. & Xin, G. (2019). Text steganography on RNN-Generated lyrics. *Mathematical Biosciences and Engineering*, 16(5), 5451–5463. <https://doi.org/10.3934/mbe.2019271>
- Wu, N., Shang, P., Fan, J., Yang, Z., Ma, W. & Liu, Z. (2019). Research on Coverless Text Steganography Based on Single Bit Rules. *Journal of Physics: Conference Series*, 1237(2). <https://doi.org/10.1088/1742-6596/1237/2/022077>
- Wu, N., Yang, Z., Yang, Y., Li, L., Shang, P., Ma, W. & Liu, Z. (2020). STBS-Stega: Coverless text steganography based on state transition-binary sequence. *International Journal of Distributed Sensor Networks*, 16(3). <https://doi.org/10.1177/1550147720914257>